

A Causal Model on Innovation Capability in Relation to Resilience, Corporate Entrepreneurship and Market Orientation of Micro, Small and Medium Enterprises in Davao Region, Philippines

Karl P. Campos, Ph.D

Assistant Professor, University of Southeastern Philippines

Francis Evan L. Manayan, Ph.D

Professional Schools Lecturer, University of Mindanao

ABSTRACT: *This quantitative study sought to discover the optimal model including the exogenous variables of resilience, corporate entrepreneurship, and market orientation in relation to the endogenous variable of innovation capability. In order to collect data, a survey questionnaire was issued to the various Micro, Small, and Medium Enterprise (MSMEs) owners and managers in Region XI. The optimum model was identified by structural equation modeling. The results reveal that resilience, corporate entrepreneurship, and market orientation are substantially related to innovation capability in MSMEs. Among the three identified exogenous variables, only resilience and market orientation emerged as important predictors of innovation capability, as depicted in the final and best-fitting model of this study. Thus, MSMEs with a strong capacity for innovation may receive a more favorable response from the environment and strengthen the required capacities to boost performance and competitive advantage.*

KEY WORD: *Resilience, Corporate Entrepreneurship, Market Orientation, Innovation Capability, Structural Equation Model, Philippines*

Date of Submission: 10-11-2022

Date of Acceptance: 23-11-2022

I. INTRODUCTION AND LITERATURE REVIEW

Small- and medium-sized firms (SMEs) have long viewed innovation as the key to their survival, growth, and evolution (Lin & Lai, 2021). Developing an organization's capacity for innovation is a mission-critical activity. Given the particularities of SMEs in terms of their environment, strategy, and technology, further research is required in this area (Gupta & Barua, 2016). These distinctions also mean that study findings in the setting of large enterprises do not automatically apply to small businesses (Eyers, Potter, Gosling, & Naim, 2018). As SMEs differ from large corporations, a greater capability for innovation is believed to compensate for their larger business environment susceptibility (Love, Roper, & Zhou, 2016).

Initiating, promoting, and implementing innovative ideas results in numerous organizational complications (Amir, 2014). For example, inventive personnel must convince others who frequently do not comprehend or who require confidence about fresh ideas. Innovative personnel are frequently hampered in their efforts by the possibility of poor evaluations and the demands to adhere to the opinions of the majority (Janssen, 2004). All of these issues necessitate that innovative employees demonstrate tenacity or resilience, and that organizations cultivate such tenacity, if new ideas are to succeed. The objective of these studies was to identify strategies for error-free operation in technologically complex environments, and they were supported by concepts such as the normal accident theory (Linnenluecke, 2017).

On the basis of the foregoing, the researcher chose to conduct this study in an effort to build the optimal model to represent the innovation capabilities of Micro, Small, and Medium-Sized Enterprises (MSMEs). This research's findings can serve as a foundation for establishing innovative and entrepreneurial programs and policies for businesses. Also, the results of this study would be of great interest to researchers, entrepreneurs, and academicians, as they can contribute to the innovation and entrepreneurship literatures and provide vital implications for a developing body of knowledge. Therefore, executing this endeavor will also be of social significance.

Because the ability to innovate is so important, a lot of research has been done to find out which metrics are linked to each other. Innovative capability was found to be strongly linked to three things: resilience (Amir, 2014), corporate entrepreneurship (Kuratko, Hornsby, & Covin, 2014), and market orientation (Smith, Pitta, & Richardson, 2007). The current techniques and frameworks don't give SMEs, in particular, clear instructions on how to improve their ability to innovate. There have also been few attempts to use a performance measurement method to build a framework for developing SMEs' ability to be innovative. Most of what is known about performance management and measurement in small and medium-sized businesses (SMEs) seems to come from traditional performance measurement studies of SMEs (Bititci, Garengo, Dorfman, and Nudurupati, 2012).

II. METHODOLOGY

Purposive sampling and a scientific process were used to choose the responders. Participants in this study included 411 Small and Medium Business owners and managers in Region XI. A survey instrument that had been adopted was used to gather primary data. The instrument's numerous elements, including resilience (Amir, 2014), corporate entrepreneurship (Kuratko et al., 2014), market orientation (Smith et al., 2007), and innovation capability, were incorporated and pulled from a variety of comparable studies (Calik, Calisir & Cetinguc, 2017).

In order to develop the most precise estimation possible, this investigation made use of a quantitative research methodology that combined descriptive correlation analysis with a model based on structural equations. A descriptive-correlation study design, which identifies the existing variables, conditions, and characteristics, is used to discuss the phenomena that is the focus of this article (Bordens & Abbott, 2002). In addition, this line of questioning is concerned with the relationship between something that is currently existing and an event that took place in the past that has influenced or affected something that is currently taking place (Johnson & Christensen, 2008). In this study, a correlational approach was taken to investigate the association between creative skills and resiliency, corporate entrepreneurship, and market orientation among MSMEs in the Davao Region.

Using structural equation modeling, the optimal model for the innovation capabilities of Micro, Small, and Medium Enterprises was determined, as well as the relationships between the hypothesized models were evaluated. Using a range of indicators (observed variables) to assess latent variables (i.e., constructs and theorized relationships between latent variables) is a particularly useful application of this technique (Hair, Sarstedt, Ringle, & Mena, 2012).

III. RESULT AND DISCUSSION

In an effort to identify the innovation capability model that provides the most satisfactory fit to the available information, five distinct models were investigated. Each model has its own built-in structure, which has the potential to be subdivided into two more compact models consisting of a measurement model and a structural model. The measurement model reflects the latent constructs of the measurement loads on each variable, whereas the structural model describes the latent variables. Both models are referred to as "latent models." In addition, the examination of the model's fit determines whether it is accepted or rejected. Within the context of this model, the researcher's overarching objectives were locating the linkages between the hypothesized models and determining which model of innovation capabilities was the one that fit the data the most effectively. When a structured model produces an appropriate fit, it demonstrates that the model's assumptions about the consistency of empirical interactions across variables are correct.

When selecting the model that provides the greatest fit, it is necessary for all of the indices to consistently fall within the acceptable limits. The ideal range for the chi-square test, which measures the degrees of freedom, should be between 0 and 2, and the p-value should be at least 0.05 or higher. A mistake was made in the root mean square. It is required that the estimated value for each Pclose value be less than 0.05 and more than or equal to 0.05, respectively. Other indices, such as the Tucker-Lewis, Comparative, and the Fit Index Goodness indices, require to have a value that is higher than 0.90.

The resilience, corporate entrepreneurship, and market orientation toward innovation capabilities networks of interrelationships are shown in Table 1's presentation of the structural model 5's goodness of fit measures. The following indices were used to check Model 5's goodness of fit, as shown in Table 8: Root Mean Square of Error Approximation (RMSEA), Normed Fit Index (NFI), Tucker-Lewis Index (TLI), Comparative Fit Index (CFI)/Goodness of Fit Index, Chi-square/Degree of Freedom (CMIN/DF), and Tucker-Lewis Index (TLI) (GFI). The criteria for each index demonstrating a satisfactory fit for all outcomes must follow the specifications listed in Table 8 in order to be valid. The results show the best fit model because

CMIN/DF=1.978, p-value =.123, NFI =.946, TLI =.935, CFI =.954, GFI =.952, RMSEA =.024 and Pclose =.231 fall inside the indices.

Table 1: Summary of Goodness of Fit Measures

Index	Criterion	Model 1	Model 2	Model 3	Model 4	Model 5
CMIN/DF	<5	9.412	5.009	5.538	5.159	1.978
p-value	>0.05	.000	.000	.000	.000	.123
NFI	>0.90	.822	.906	.926	.935	.946
TLI	>0.90	.815	.914	.926	.934	.935
CFI	>0.90	.838	.923	1.000	.947	.954
GFI	>0.90	.745	.828	.864	.877	.952
RMSEA	<0.05	.142	.099	.105	.101	.024
Pclose	>0.05	.000	.000	.000	.000	.231

Figure 1 depicts the structural model that was developed by step 5, which demonstrates the direct link that exists between the latent exogenous variables and their direct effect on the latent endogenous variable. The endogenous latent variable in the model is the Innovation Capability (INC) with observed variables namely Product Innovation (PDI), Organizational Innovation (ORI), Process Innovation (PRI) and Innovation Culture (ICL). There are only two exogenous latent variables namely: Resilience (RES) which is measured by Perseverance (PER), Meaning Making (MEM) and Positive Emotion (POE) while Market Orientation (MOR) is gauged by Customer Orientation (CSO), Intelligence Generation (INGO and Responsiveness (RPN).

Figure 1: Structural Model 5 in Standardized Solution

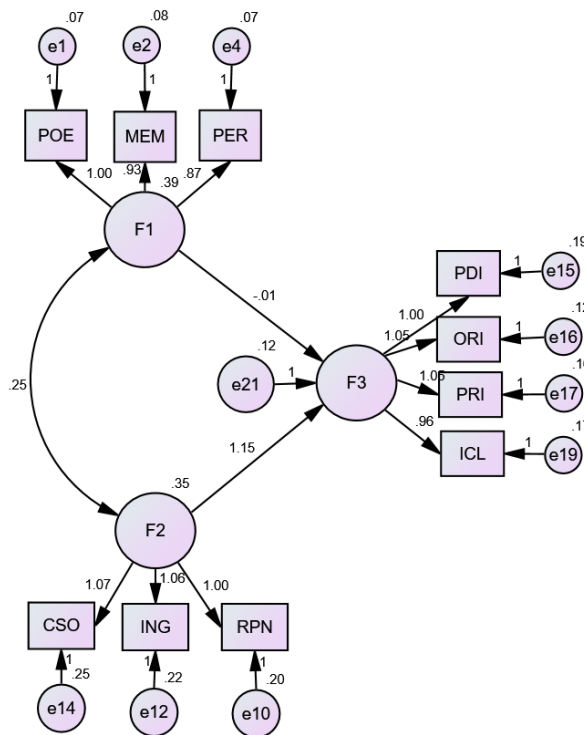

This model clearly highlights the significance of market orientation and resilience as the primary factors that serve as predictors of innovation aptitude among MSEs (micro, small, and medium businesses). For entrepreneurs to be successful in exploring new innovative ventures that will lead to increased productivity and profits, resiliency and market orientation play a significant influence. According to the findings, the innovation capability appears to be best grounded on the strong evidence of resilience and market orientation that the company possesses. Moreover, it corroborates the framework provided by Janssen et al. (2004), which suggests that the potential for negative evaluations and the pressures to conform to the majority in order to be resilient frequently hinder inventive employees' ability to sustain their efforts. Therefore, it is essential to recognize that a company is unlikely to thrive if its business practices lack a market-oriented culture, such as the ability to drive innovation (Attia, 2013).

IV. CONCLUSION AND RECOMMENDATION

The study's findings serve as the basis for the subsequent conclusions. The structural model defines the latent variables, whereas the measurement model reflects the latent constructs underlying the measurement loads on each variable. Since the final model measures fall within the indices, the result represents the model with the best fit. This study indicated that among Micro, Small, and Medium-Sized Enterprises (MSME) in Region XI, market orientation and resilience were the most significant determinants of innovation capability. Strong innovation capabilities may allow SMBs to better adapt to their environment and acquire the skills required to boost performance and competitive advantage. The success of a company's creative activities is determined by its capacity to endure in the face of competition. As a result, the null hypothesis that there is no model that best represents the innovative ability of MSMEs was rejected.

In light of the study's findings and recommendations, the following suggestions are offered. According to the findings, corporate entrepreneurship appears to have a poor mean score. It is advised that MSMEs evaluate prospective new prospects, resource alignment, exploitation, commercialization, and even take into account innovation that is appropriate to its operation. Additionally, it is advised that business owners work to strengthen their resilience and recognize their own entrepreneurial potential in order for their organizations to increase their capacity for innovation. In order to respond to market demands and the dynamic of the entrepreneurial scene, businesses may continue to look for and consider new processes, technologies, and systems. Future researchers are advised to focus on and explore additional dimensions and aspects that drive innovation capabilities, enterprise continuity management, and productivity-boosting constructs.

BIBLIOGRAPHY

- [1]. Amir, M. T., 2014. The role of resilience in individual innovation.
- [2]. Attia, S. T. M., 2013. Market orientation in an emerging economy–Egypt. *Journal of Strategic Marketing*, 21(3), 277-291.
- [3]. Bititci, U., Garengo, P., Dörfler, V., & Nudurupati, S., 2012. Performance measurement: challenges for tomorrow. *International journal of management reviews*, 14(3), 305-327.
- [4]. Bordens, K.S. and Abbott, B.B., 2002. *Research Design and Methodology*.
- [5]. Calik, E., Calisir, F., & Cetinguc, B., 2017. A scale development for innovation capability measurement.
- [6]. Eysers, D. R., Potter, A. T., Gosling, J., & Naim, M. M., 2018. The flexibility of industrial additive manufacturing systems. *International Journal of Operations & Production Management*.
- [7]. Gupta, H., & Barua, M. K., 2016. Identifying enablers of technological innovation for Indian MSMEs using best–worst multi criteria decision making method. *Technological Forecasting and Social Change*, 107, 69-79.
- [8]. Hair, J. F., Ringle, C. M., & Sarstedt, M., 2013. Partial least squares structural equation modeling: Rigorous applications, better results and higher acceptance. *Long range planning*, 46(1-2), 1-12.
- [9]. Janssen, O., Van de Vliert, E., & West, M., 2004. The bright and dark sides of individual and group innovation: A special issue introduction. *Journal of organizational behavior*, 25(2), 129-145.
- [10]. Kuratko, D. F., Hornsby, J. S., & Covin, J. G., 2014. Diagnosing a firm's internal environment for corporate entrepreneurship. *Business Horizons*, 57(1), 37-47.
- [11]. Lin, F. J., & Lai, C., 2021. Key factors affecting technological capabilities in small and medium-sized Enterprises in Taiwan. *International Entrepreneurship and Management Journal*, 17(1), 131-143.
- [12]. Linnenluecke, M. K., 2017. Resilience in business and management research: A review of influential publications and a research agenda. *International Journal of Management Reviews*, 19(1), 4-30.
- [13]. Love, J. H., Roper, S., & Zhou, Y., 2016. Experience, age and exporting performance in UK SMEs. *International Business Review*, 25(4), 806-819.
- [14]. Smith, D. B., Pitta, D. A., & Richardson, L., 2007. A Comparison of the Market Orientation of Chinese and US Firms. *International Business & Economics Research Journal (IBER)*, 6(12).

Karl P. Campos, Ph.D, et. al. " A Causal Model on Innovation Capability in Relation to Resilience, Corporate Entrepreneurship and Market Orientation of Micro, Small and Medium Enterprises in Davao Region, Philippines." *International Journal of Business and Management Invention (IJBMI)*, vol. 11(11), 2022, pp. 43-46. Journal DOI- 10.35629/8028